

SAMPLING VALVE GSV

Hygienic and convenient solution for sample taking from production line



The sampling valve allows the operator to extract a sample of the product from the production line or reactor and safely store it for transportation to the laboratory where it will be analyzed or to the archive room where it can be retrieved for further use. The Gericke sampling valve is designed according to the latest construction standards and recognized safety rules.

+ Applications

- Suitable for chemical, plastic, food, pharmaceutical industries.
- Used in production process that allows taking a representative portion of powder (gassed, liquid, solid, or slurries) to test.
- Typically for the purposes of identification, quality control or regulatory assessment.
- POM material used in body.

+ Advantages

- A sample can be taken during the process to ensure that the output meets specifications before further processing.
- The valve is designed such that effective cleaning and sampling can be carried out regularly without interrupting the production process.
- Simple, safe and effective solution.
- Made of stainless steel, it complies with stringent requirements for the food, chemical, pharmaceutical and plastic industries.
- Eliminating material lost.

SEMI-AUTOMATIC OPERATION

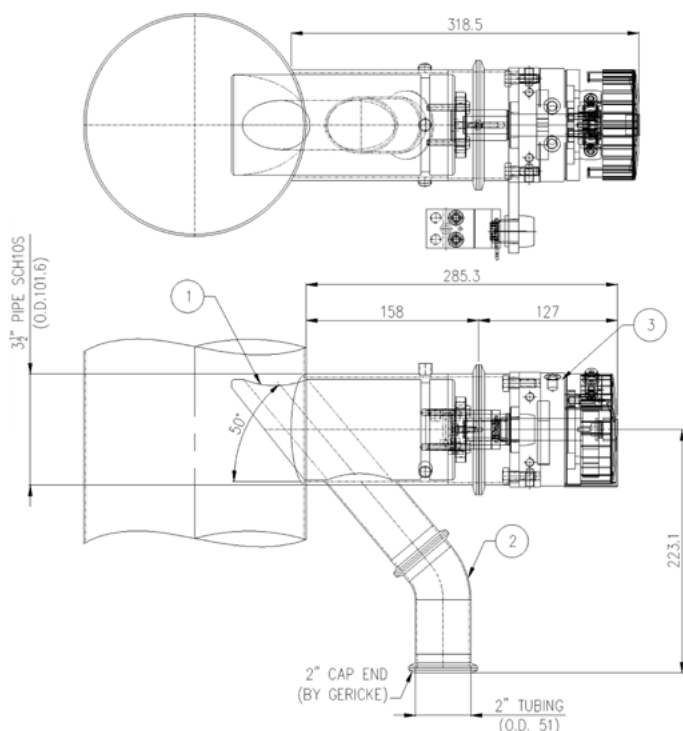

- ① Sample inlet
- ② Sample outlet
- ③ Swivel module
- ④ Control valve

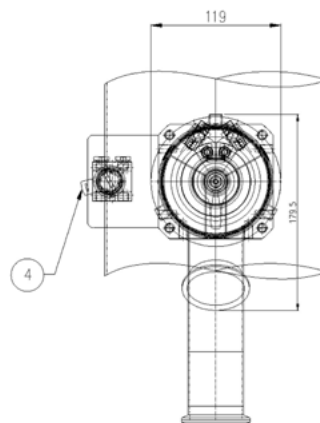

MANUAL OPERATION

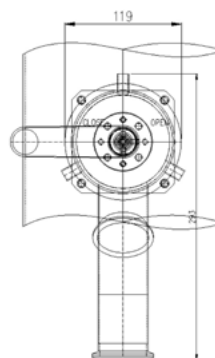
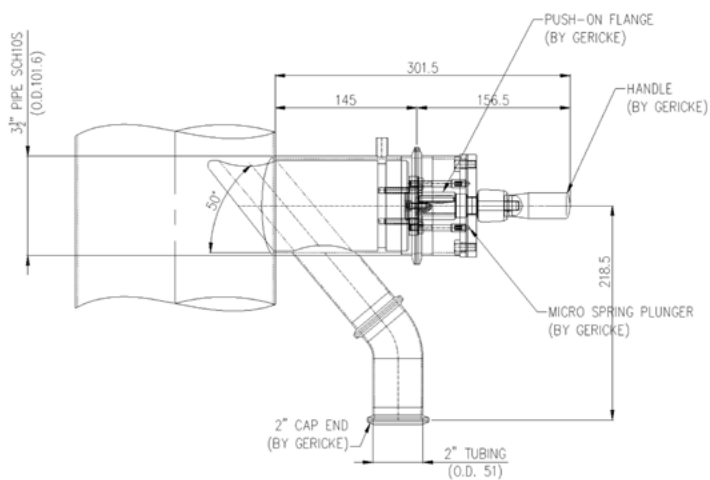
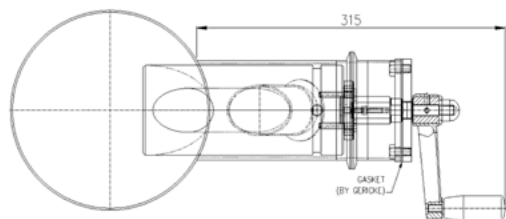

All dimensions in mm.