

# POWDER PROCESSING SOLUTIONS FOR BATTERY CELL PRODUCTION

From bulk material handling to conveying, feeding and mixing of fine powders: Gericke has the solutions to handle toxic, high value and sensitive raw materials for the anode and cathode production in a safe and efficient way.





# BATTERIES MOVE THE WORLD!



The efficient production of batteries, used for many different purposes, is a key in the drive to meet our climate change promises and the success of renewable energies. Additionally, the reuse of battery components will ensure a sustainable path for this type of high value energy.

Gericke equipment is used in different parts of battery production, from the feeding of rotary kilns and extruders for raw material manufacture to the storage, delivery and blending necessary for anode and cathode slurry manufacture. Gericke can also provide systems to help in the recovery and the successful recycling of precious rare earth elements.



## THE EXPERTS IN POWDER HANDLING

Benefit from our wealth of experience in respect of powder handling, dosing, pneumatic conveying systems and mixing technology. We know how to handle very fine or cohesive powders, as well as abrasive, sensitive, toxic and explosive materials.

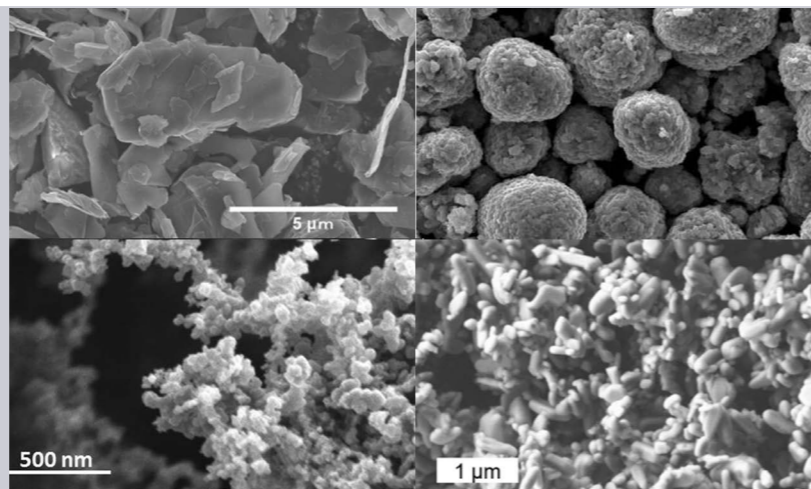

## YOUR ENGINEERING PARTNER

Save time and money with competent engineering and project management! This also covers risk assessment, data integration and energy efficiency. We are also available to consult you with a pre-engineering study!

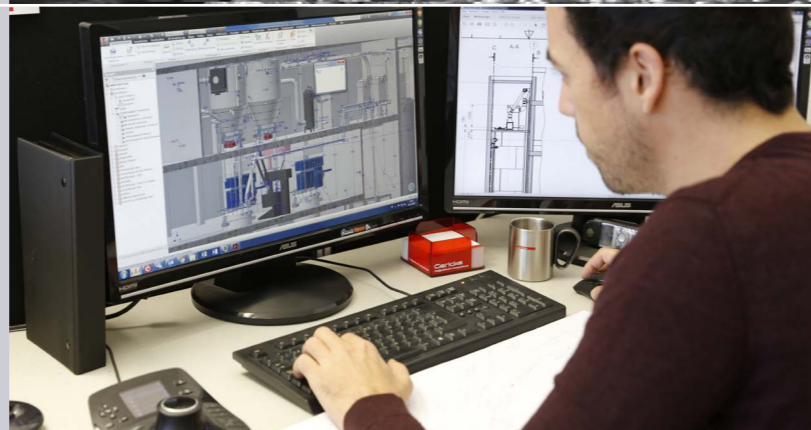

# FIT FOR YOUR NEEDS

## SAFE TO OPERATE, FOR THE PRODUCTION AND THE ENVIRONMENT!

Gericke engineers its solutions to protect you and our planet! Since some of the raw materials are hazardous to health, our systems are designed to be dust-tight and fully compliant to containment standards. We use proven sealing technologies also to ensure that moving parts are perfectly tight.



## HANDLE PRECIOUS RAW MATERIALS THE RIGHT WAY!

Gericke metering systems ensure a very high consistent quality in the processing of active materials such as NMC, NCA, LFP, LCO, LFP, binders, conductive carbon blacks, graphite, silicone, carboxymethyl cellulose (CMC) and polyvinylidene fluorides (PVDF).

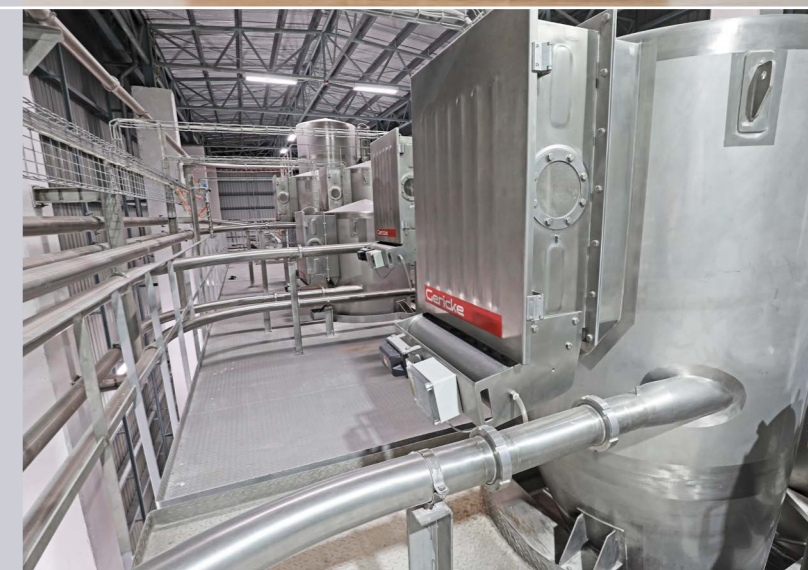

## AVOID METAL CONTACT AND CONTAMINATION

Our solutions are available in special executions to avoid metallic contamination, helping you to achieve a superior high quality end product.





# YOUR GLOBAL PARTNER FOR ALL ASPECTS OF POWDER PROCESSING

- 1 Bulk Handling: Safe and contained**
  - Gericke handling systems combine key needs: Preserve material quality, save energy, protect the environment and the workers.
- 2 Accurate feeding into mixing, extrusion and grinding**
  - Reliable and accurate, Gericke covers a broad range of feeding and dosing requirements.
  - Extruders and mixers require accurate control of several material streams. Our multichannel controllers offer a cost effective solution.
- 3 Automation: Integrated and preconfigured**
  - Our understanding of the fundamental processes of bulk handling, feeding, mixing and conveying together with our competence in electrical engineering and automation makes us the ideal partner to supply you with complete turn-key systems.

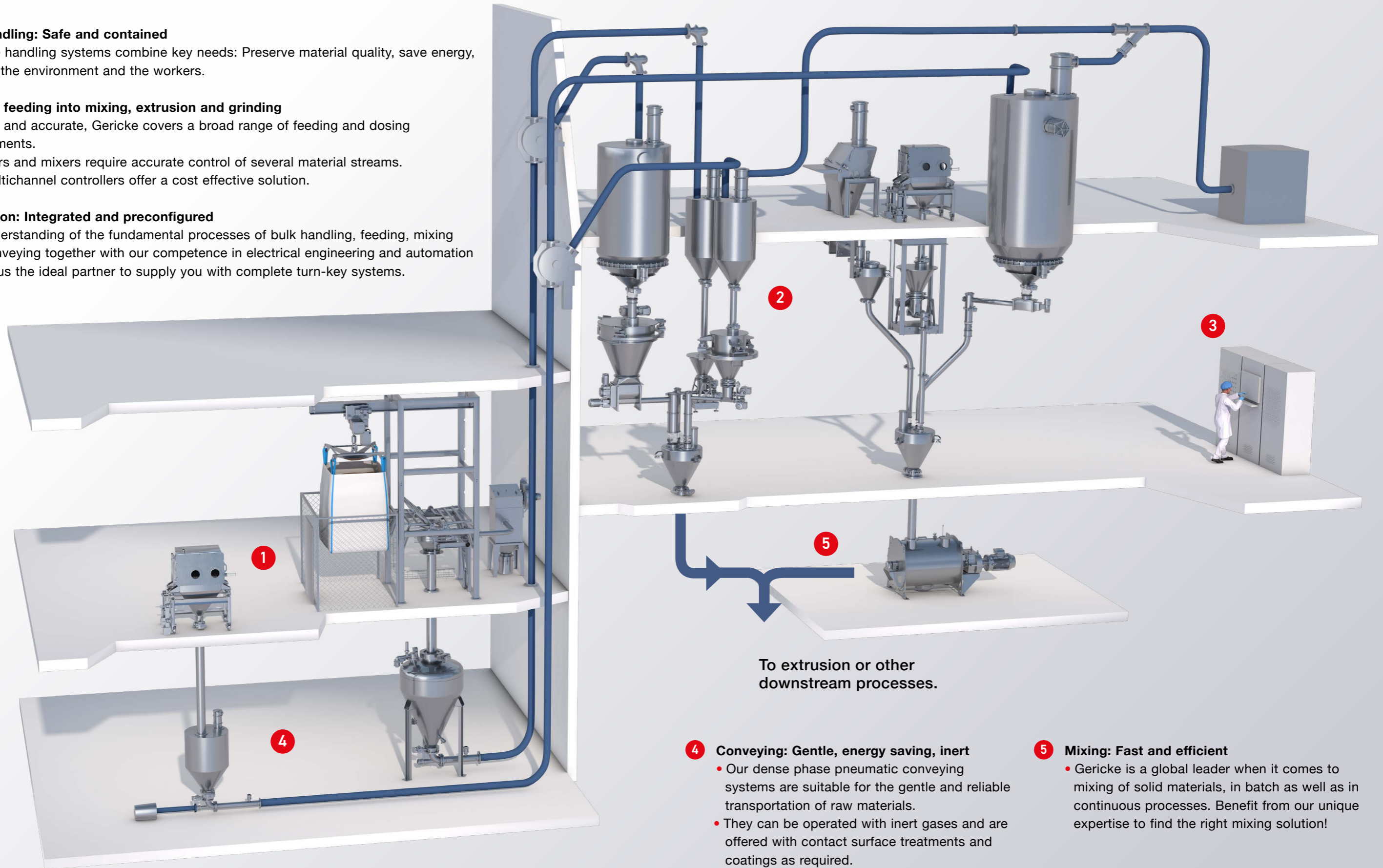

- 4 Conveying: Gentle, energy saving, inert**
  - Our dense phase pneumatic conveying systems are suitable for the gentle and reliable transportation of raw materials.
  - They can be operated with inert gases and are offered with contact surface treatments and coatings as required.
- 5 Mixing: Fast and efficient**
  - Gericke is a global leader when it comes to mixing of solid materials, in batch as well as in continuous processes. Benefit from our unique expertise to find the right mixing solution!

# DENSE PHASE PNEUMATIC CONVEYING

Automated, robust, efficient, safe, reliable

For gentle and energy efficient product transfer with no demixing, dense phase conveying is the perfect solution to preserve your materials.

- Low velocity convey speeds give much reduced wear and chance of metal contamination
- Gas and dust tight systems that result in no pollution - protecting the local environment and system operators
- High solids concentration with low gas consumption leads to reduced operation costs
- Utilizing dried pressurized air or inert gases with low air humidity (<math><1\text{g}/\text{m}^3</math>) prevents problems with moisture / humidity
- Additional wear protection and coating solutions available
- Best in class availability with long operating life all combined with minimal maintenance

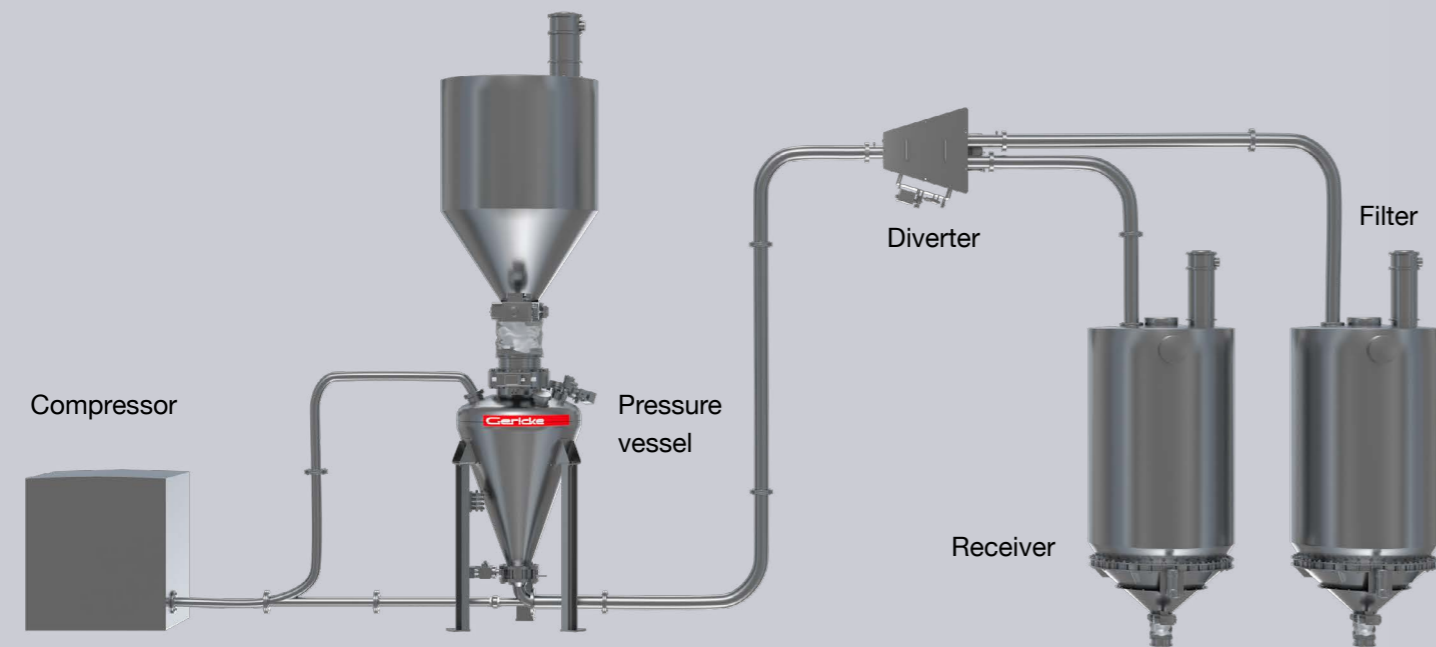

# DILUTE PHASE PNEUMATIC CONVEYING

Easy to implement and versatile

Lean or dilute phase conveying can be the perfect solution for many nonsensitive powders and bulk materials.

- Gericke lean phase conveying systems are economical and reliable solutions
- Systems can be setup in vacuum or overpressure configurations
- Simple setup of the system
- Little headroom necessary for installation
- The throughput can be varied by controlling the rotational speed of the rotary valve
- Gericke RotaVal rotary valves are available as easy to clean extractable units, with re-enforced replaceable blade inserts or with special coatings

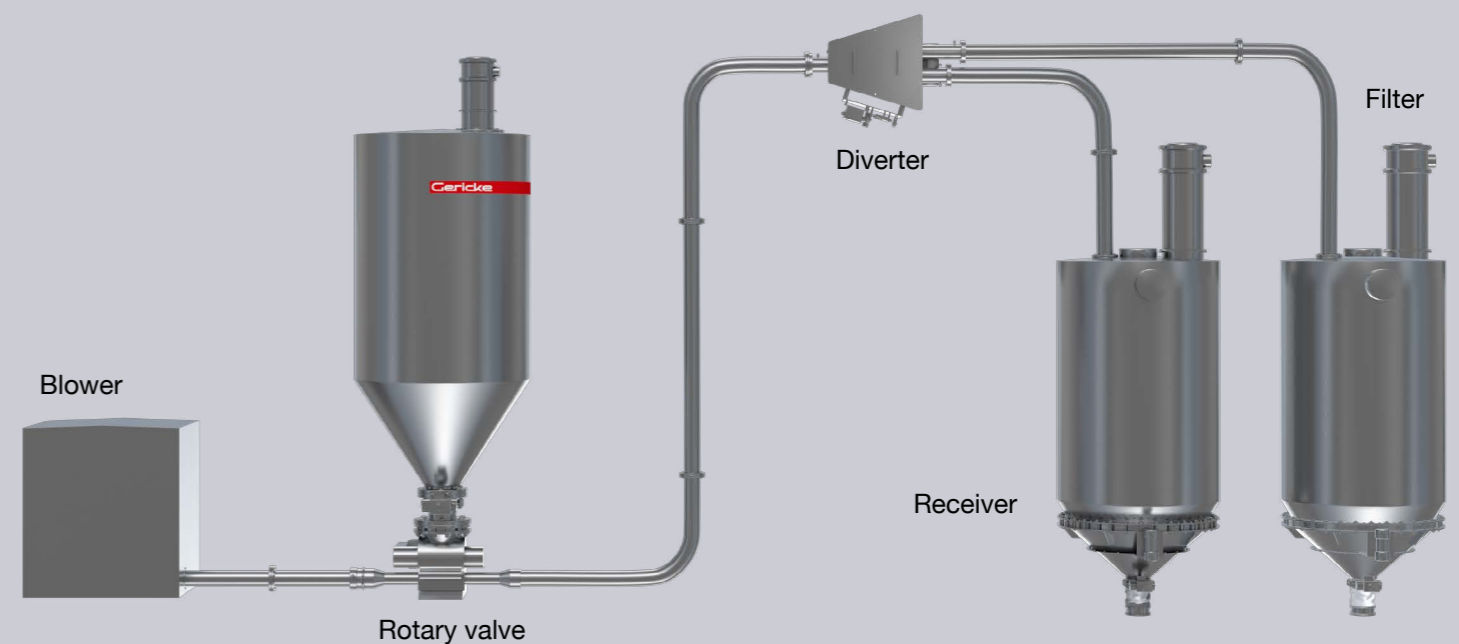



# VOLUMETRIC AND GRAVIMETRIC FEEDING AND DOSING

## MAKE NO COMPROMISE ON ACCURACY & TIGHTNESS!

Gericke feeders combine simple operation with easy cleaning and minimal maintenance. Thanks to its modular design, it is versatile and highly adaptable to suit both the bulk material and the process.

### Tight. Period.

Many Gericke feeders are available with an advanced sealing concept. Using lip seals on the drive shafts of the feeding tool and intruder, the feeder is extremely tight, even at the critical interfaces to the moving parts. This makes our feeders a perfect dosing device in industries with demanding OEL requirements.

### Designed for highest accuracy

Gericke's gravimetric feeders combine advanced volumetric feeders with precise load detection and sophisticated controls to guarantee the highest accuracy for all loss-in-weight applications.



Feeder with internal surface coating in high temperature execution.

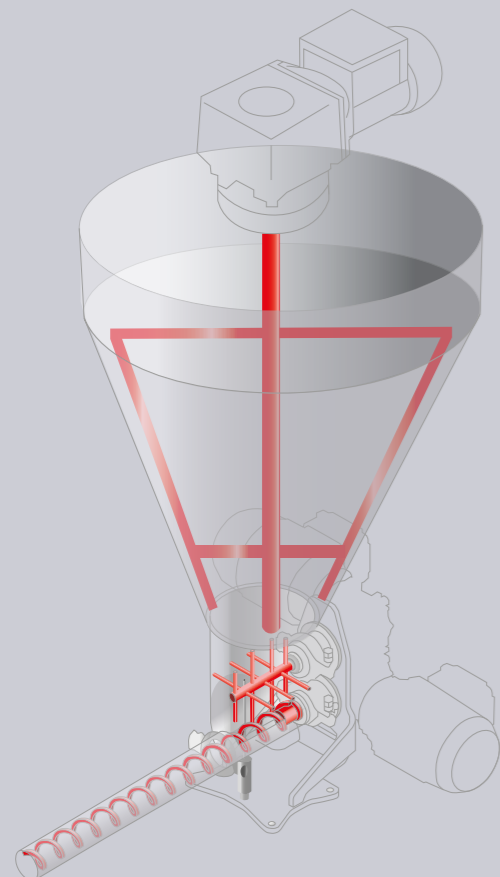

## MULTIPLE FEEDERS NEEDED?

Gericke has been a specialist for highly accurate feeding and dosing even under harshest conditions. With our multichannel controller GUC-F you can now easier than ever control different feeders with one state-of-the-art and flexible electronics. Integrated to your factory automation, ready for "IoT" and with optional touch display, it is the most flexible feeding and dosing solution on the market.



## HIGH TEMPERATURES? NO WORRIES.

Gericke has developed an extremely accurate metering system for the direct dosing of material into high temperature rotary kilns used in the synthesis of materials in the anode and cathode production.

From there, Gericke also offers metering systems for the delivery of the high temperature powders for grinding.

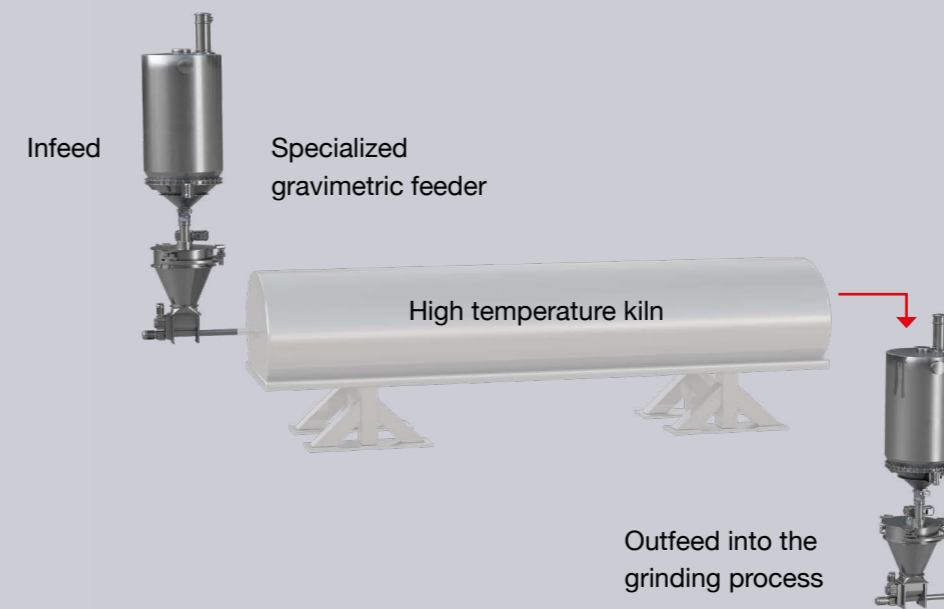



# BATCH AND CONTINUOUS INLINE MIXING SOLUTIONS

The highest homogeneity, even with microingredients. Easy to clean, fast and effective but nevertheless gentle, energy efficient and space saving. Fully integrated with feeders and with your entire process: That is mixing technology from Gericke.

## Mixing: Fast and efficient

Gericke covers inline mixing ranges from 1 kg/h to more than 100,000 kg/h for powders, pellets, granules, flakes, particles and liquid additions.

Gericke's unique experience also includes reaction processes such as agglomeration, coating and heat transfer.



## Meeting all requirements

- Available in continuous and batch executions
- Batch sizes from 1 l up to 40'000 l
- Integrated with Gericke feeding and dosing equipment
- Optional cooling and heating jackets
- High product temperature executions
- Special surface coatings

# READY FOR DRY PROCESSING?

Gericke has gained expertise in the mixing of lubricants into a powder stream in the pharmaceutical industry. If liquid binders are replaced by new advanced dry binder materials, you may profit from our experience handling fine powders continuously, under containment conditions and to a maximum degree of mixing.



## NEED FOR SMALL BATCHES?

The GMS Compact Mixer brings the superb mixing quality and speed of the GMS family to laboratory and R&D size, with useable volumes from 1 to 20 l. The industrial design also makes it a perfect fit for pilot plants and small production batches.

- Optional cooling and heating jackets
- High product temperature executions
- Interchangeable mixing chambers







## TEST CENTRE

**Tests on an industrial scale reduce planning time and increase process safety!**

Test centres in Switzerland, France, England, Brazil, USA and Singapore are available for customer tests under near-production conditions. The test centres are equipped with original machines. Experienced specialists design the test layout according to your wishes and perform the tests.

- Testing of machines and prototypes with original products
- Checking of performance ranges and accuracies
- Testing of the interaction of multiple machines
- Gaining of experience for product processing
- Sampling for laboratory tests and market response
- Customer training

## SERVICE

**Worldwide support for commissioning, maintenance and service.**

We highly value punctual delivery, reliable assembly and thorough assembly monitoring. With well-planned commissioning and intensive on-site training we create the prerequisites for a smooth production start-up. Our service team and the global spare parts service combine to ensure long service life and high availability of systems with consistent product quality.

## YOUR PARTNERS WORLD-WIDE

### Switzerland

Gericke AG  
T +41 44 871 36 36  
gericke.ch@gerickegroup.com

### Germany

Gericke GmbH  
T +49 77 31 929 0  
gericke.de@gerickegroup.com

### France

Gericke SAS  
T +33 1 39 98 29 29  
gericke.fr@gerickegroup.com

### United Kingdom

Gericke Ltd.  
T +44 16 13 44 11 40  
gericke.uk@gerickegroup.com

### Netherlands

Gericke B.V.  
T +31 33 25 42 100  
gericke.nl@gerickegroup.com

### USA

Gericke USA, Inc.  
T +1 855 888 0088  
gericke.us@gerickegroup.com

### Brazil

Gericke Brasil Ltda.  
T +55 11 2598 2669  
gericke.br@gerickegroup.com

### Singapore

Gericke Pte Ltd.  
T +65 64 52 81 33  
gericke.sg@gerickegroup.com

### China

Gericke (Shanghai) Pte Ltd.  
T +86 21 3306 3395  
gericke.cn@gerickegroup.com

### Indonesia

Gericke Indonesia  
T +62 21 2958 6753  
gericke.id@gerickegroup.com

### Thailand

Gericke Thailand  
T +66 95 464 6161  
gericke.th@gerickegroup.com

### Malaysia

Gericke Malaysia  
T +60 11 51678133  
gericke.my@gerickegroup.com

For all other countries please contact Gericke AG in Switzerland.

**GERICKEGROUP.COM**

**Gericke**